

SERIE

R

CILINDRI CORSA BREVE
SHORT STROKE CYLINDERS



ARTEC[®]
PNEUMATIC COMPONENTS

CARATTERISTICHE TECNICHE - TECHNICAL CHARACTERISTICS

Pressione di esercizio <i>Working pressure</i>	1 ÷ 10 bar (doppio effetto - <i>double acting</i>) 2 ÷ 10 bar (semplice effetto - <i>single acting</i>)
Temperatura di esercizio <i>Working temperature</i>	0 ÷ +80 °C (-20 °C con aria secca - <i>with dry air</i>)
Versioni - Versions	semplice effetto (molla anteriore) - <i>single acting (front spring)</i> doppio effetto - <i>double acting</i>
Alesaggi - Bores	Ø 8 - 12 - 20 - 32 - 50 - 63
Corse - Strokes	vedere tabelle corse standard - <i>see standard stroke tables</i>
Fluido - Fluid	aria compressa, filtrata, non lubrificata - <i>compressed air, filtered, no lubrication</i>

CARATTERISTICHE COSTRUTTIVE - CONSTRUCTIVE CHARACTERISTICS

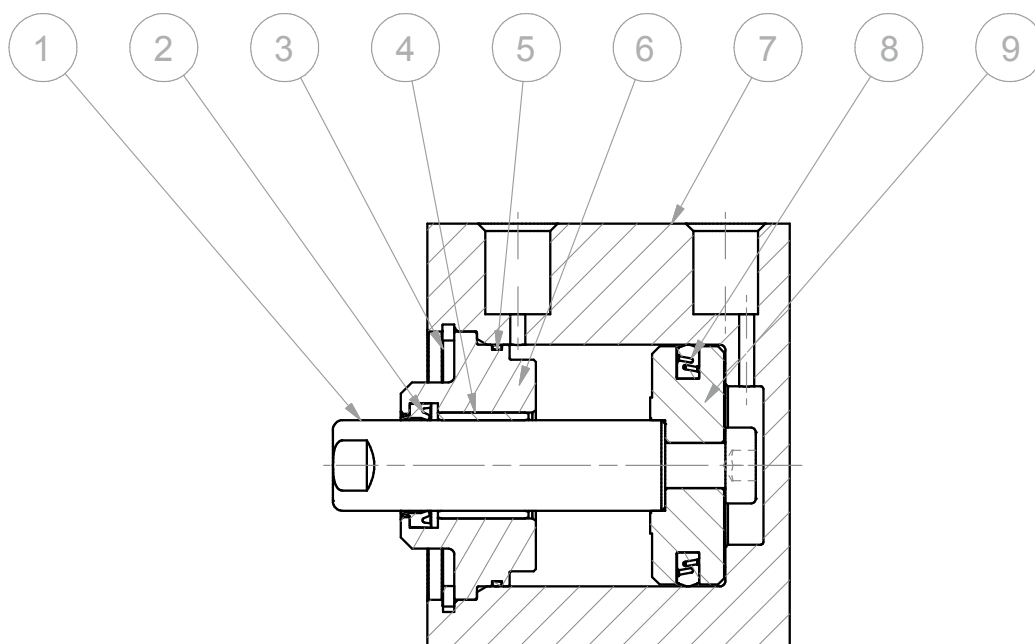
①	Stelo - Rod	acciaio inox AISI 303 - <i>stainless steel AISI 303</i>
②	Guarnizione - Seal	poliuretano - <i>polyurethane</i>
③	Testata - Cover	Ø 8 - 12 - 20 ottone - <i>brass</i> Ø 32 - 50 - 63 alluminio anodizzato - <i>anodized aluminium</i>
④	Boccola - Bush	acciaio+PTFE - <i>steel+PTFE</i>
⑤	O-ring	nbr
⑦	Tubo - Tube	alluminio anodizzato - <i>anodized aluminium</i>
⑧	Guarnizione - Seal	nbr
⑨	Pistone semplice effetto <i>Piston single acting</i>	Ø 8 - 12 acciaio inox AISI 303 - <i>stainless steel AISI 303</i> Ø 20 alluminio - <i>aluminium</i> Ø 32 - 50 - 63 delrin - <i>delrin</i>
⑨	Pistone doppio effetto <i>Piston double acting</i>	Ø 12 - 20 alluminio - <i>aluminium</i> Ø 32 - 50 - 63 delrin - <i>delrin</i>
	Molla - Spring	acciaio - <i>steel</i>



CHIAVE DI CODIFICA

KEY CODE

R D 0 1 2 . 0 1 0 . G S . M		
ALESAGGIO - BORE (Ø)	008 - 012 - 020	CORSA - STROKE (mm) vedere tabelle corse std see std stroke tables
	032 - 050 - 063	
VERSIONE - VERSION		
S	semplice effetto molla anteriore single acting front spring	
D	doppio effetto double acting	
STELO - ROD		
F	femmina female	
M	maschio male	
L	liscio smooth	
GUARNIZIONI - SEALS		
GS	guarnizioni standard standard seals	
SERIE - SERIES		
R	barra piena di alluminio aluminium solid bar	

FORZE TEORICHE MINIME DELLE MOLLE

RS

 SERIE
R

THEORETICAL MINIMUM SPRING FORCES

	FORZA TRAZIONE [N] TRACTION FORCE [N]	FORZA DI BLOCCAGGIO [N] LOCKING FORCE [N]	CARICO MAX [g] MAX LOAD [g]
RS008.004.GS.L	3,2	25	-
RS012.004.GS.L	5	55	25
RS012.010.GS.L	7	53	25
RS020.004.GS.F	7	170	75
RS020.010.GS.F	15	160	75
RS020.025.GS.F	13	157	75
RS032.005.GS.F	28	454	100
RS032.010.GS.F	23	459	100
RS032.025.GS.F	21	461	100
RS050.010.GS.F	53	1080	200
RS050.025.GS.F	49	1075	200
RS063.010.GS.F	67	1765	250
RS063.025.GS.F	73	1735	250

FORZE TEORICHE DI TRAZIONE (P=6bar)

RD

THEORETICAL FORCES OF TRACTION (P=6bar)

	Ø	012	020	032	050	063
RD	SPINTA THRUST [N]	68	189	483	1.178	1.870
	TRAZIONE TRACTION [N]	51	141	415	1.056	1.750

SEMPLICE EFFETTO - MOLLA ANTERIORE

SINGLE ACTING - FRONT SPRING

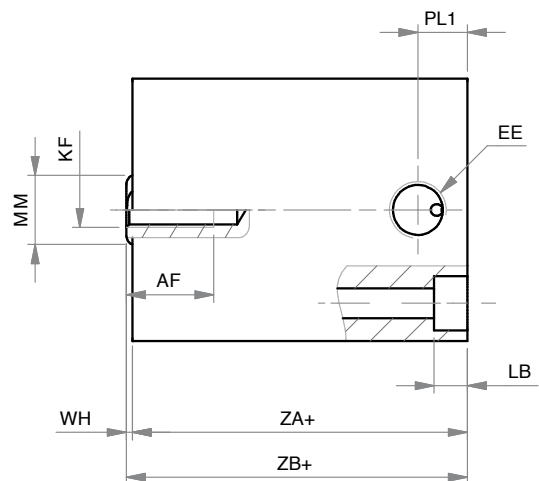
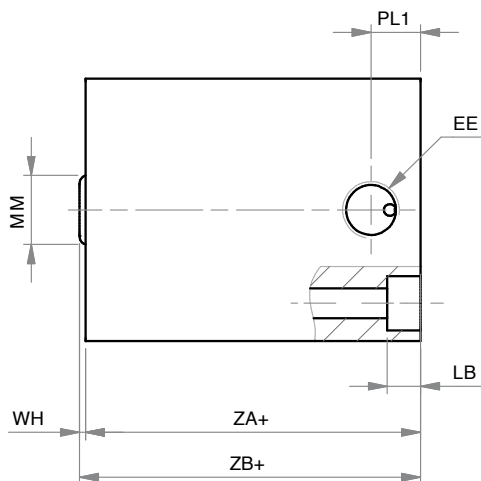
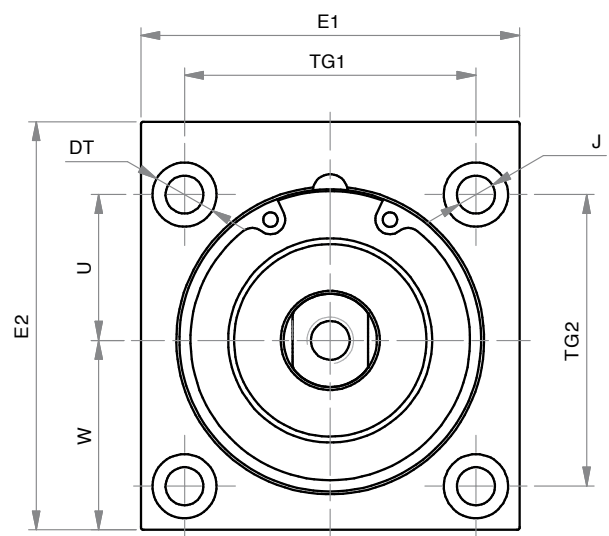
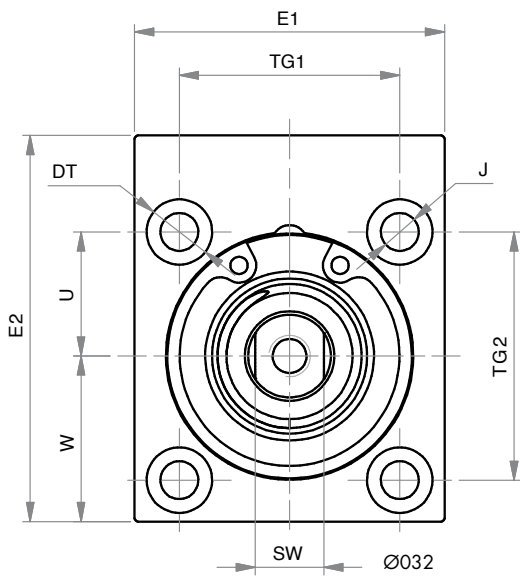
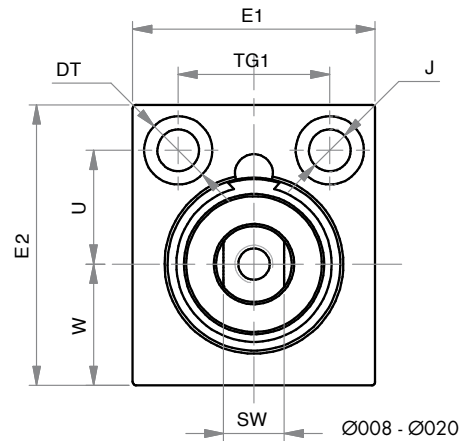
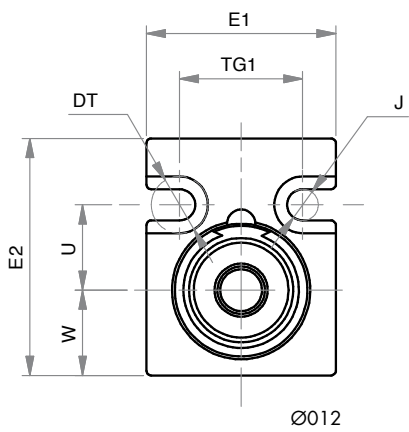
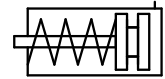

DIMENSIONI - DIMENSIONS

Ø	RS008.004.GS.L	RS012.004.GS.L	RS012.010.GS.L	RS020.004.GS.F	RS020.010.GS.F	RS020.025.GS.F	RS032.005.GS.F
AF	-	-	-	9	10	10	10
ø DT	6	6	6	9	9	9	9,5
E1	18	20	20	32	32	32	45
E2	20	25	25	37	37	37	56
EE	M5	M5	M5	M5	M5	M5	G1/8
KF	-	-	-	M5	M5	M5	M6
LB	3,1	3,4	3,4	5,5	5,5	5,5	5,7
ø MM	4	5	5	10	10	10	12
ø J	3,4	3,3	3,3	5,5	5,5	5,5	5,3
PL1	5,5	6	6	5	5	5	8,5
SW	-	-	-	8	8	8	10
TG1	11	13	13	20	20	20	32
TG2	-	-	-	-	-	-	36
U	8	9	9	15	15	15	18
W	6,5	9	9	16	16	16	24
WH	1	1	4	1	1	1	1
ZA+	12	12	16	16	22	28	21
ZB+	13	13	20	17	23	29	22

+ = aggiungere lunghezza corsa (mm) - add stroke length (mm)

DIMENSIONI - DIMENSIONS

Ø	RS032.010.GS.F	RS032.025.GS.F	RS050.010.GS.F	RS050.025.GS.F	RS063.010.GS.F	RS063.025.GS.F
AF	14,5	14,5	10,5	15,5	14,5	14,5
DT	9,5	9,5	11	11	14	14
E1	45	45	65	65	80	80
E2	56	56	70	70	85	85
EE	G1/8	G1/8	G1/8	G1/8	G1/8	G1/8
KF	M6	M6	M8	M8	M8	M8
LB	5,7	5,7	6,8	6,8	9	9
MM	12	12	16	16	16	16
ø J	5,3	5,3	6,5	6,5	9	9
PL1	8,5	8,5	7,5	8	8	8
SW	10	10	13	13	13	13
TG1	32	32	50	50	62	62
TG2	36	36	50	50	62	62
U	18	18	25	25	31	31
W	24	24	32,5	32,5	40	40
WH	1	1	1	1	1	2
ZA+	22	32,5	20	32,5	25	35,5
ZB+	23	33,5	21	33,5	26	37,5

+ = aggiungere lunghezza corsa (mm) - add stroke length (mm)

CORSE STANDARD - STANDARD STROKES

Ø	008	012	020	032	050	063
004	X	X	X			
005				X		
010		X	X	X	X	X
025			X	X	X	X

STELI STANDARD - STANDARD PISTON RODS

Ø	008	012	020	032	050	063
FEMMINA - FEMALE		X	X	X	X	X
MASCHIO - MALE						
LISCIO - SMOOTH	X	X				

DOPPIO EFFETTO

DOUBLE ACTING

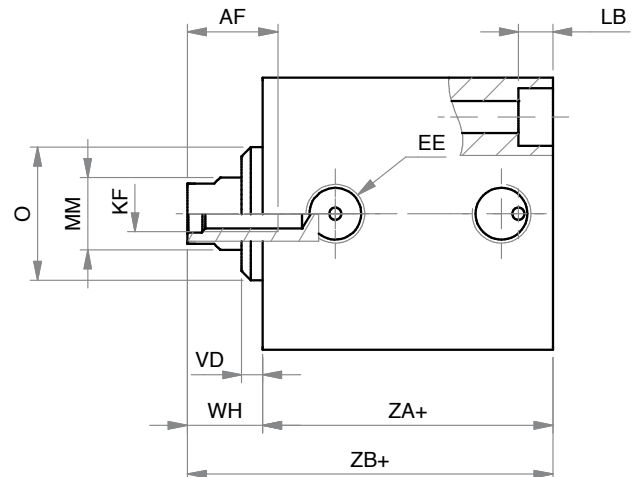
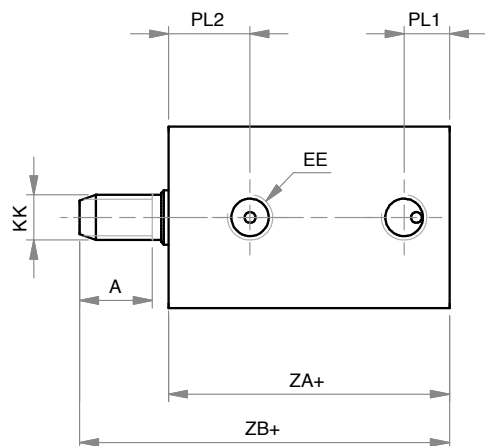
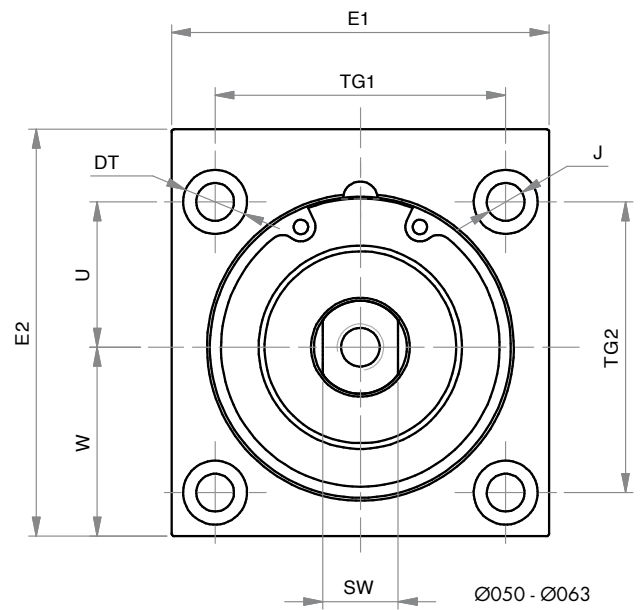
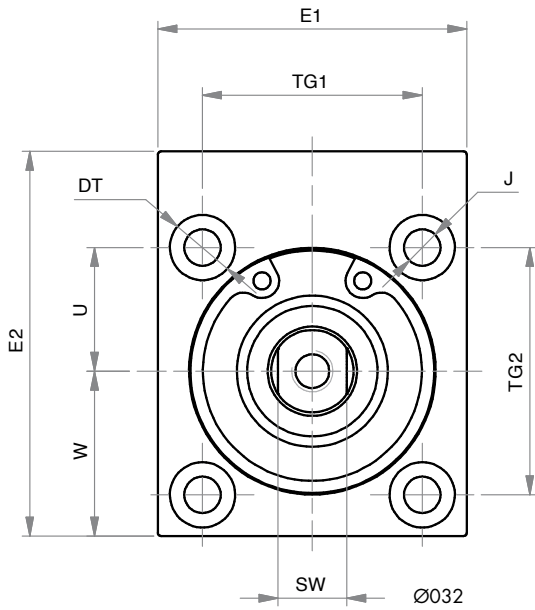
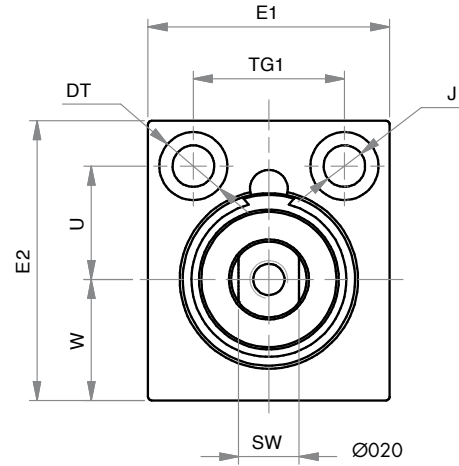
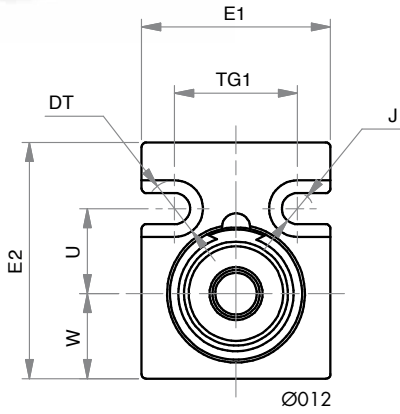
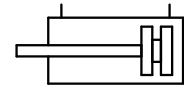

DIMENSIONI - DIMENSIONS

	012	020	032	050	063
Ø	012	020	032	050	063
A	9	-	-	-	
AF	-	10	15	17	17
Ø DT	6	9	9,5	11	14
E1	20	32	45	65	80
E2	25	37	56	70	85
EE	M5	M5	G1/8	G1/8	G1/8
KF	-	M5	M6	M8	M8
KK	M5	-	-	-	-
LB	3,4	5,5	5,7	6,8	9
Ø MM	6	10	12	16	16
Ø J	3,3	5,5	5,3	6,5	9
Ø O	-	-	22	35	35
PL1	5	5	8,5	9	8
PL2	9	8,5	12	11	13
SW	-	8	10	13	13
TG1	13	20	32	50	62
TG2	-	-	36	50	62
U	9	15	18	25	31
VD	-	-	3,5	6	6,5
W	9	16	24	32,5	40
WH	1	9,5	12,5	17	17
ZA+	21	24,5	33	32,5	35,5
ZB+	31	34	45,5	49,5	52,5

+ = aggiungere lunghezza corsa (mm) - add stroke length (mm)

SERIE
R

CORSE STANDARD - STANDARD STROKES

Ø	012	020	032	050	063
005	X	X			
010	X	X	X	X	X
015	X	X	X	X	X
020	X	X	X	X	X
025	X	X	X	X	X
030	X	X	X	X	X

STELI STANDARD - STANDARD PISTON RODS

Ø	012	020	032	050	063
FEMMINA - FEMALE		X	X	X	X
MASCHIO - MALE	X				
LISCIO - SMOOTH					