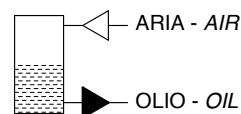

SERIE

S

SERBATOI
RESERVOIRS

ARTEC[®]
PNEUMATIC COMPONENTS

SERBATOIO ARIA/OLIO
AIR-OIL RESERVOIRS

I serbatoi (o compensatori) aria/olio SER, vengono utilizzati principalmente per controllare la velocità dei cilindri pneumatici, realizzando un circuito oleopneumatico, come da schemi sotto riportati. La regolazione della velocità del cilindro viene effettuata mediante regolatore di flusso unidirezionale.

Il SER deve essere installato ad un livello superiore a quello del cilindro, e deve avere un volume maggiore del 20% rispetto al volume del cilindro.

The air/oil reservoirs (or tanks) SER, are used mainly to control the speed of pneumatic cylinders, creating a hydro-pneumatic circuit, as shown in the diagram below.

The speed of the cylinder is obtained by using a one-way flow regulator.

The reservoir must be installed in a higher position than the cylinder's; its volume must be by 20% bigger than the cylinder volume.

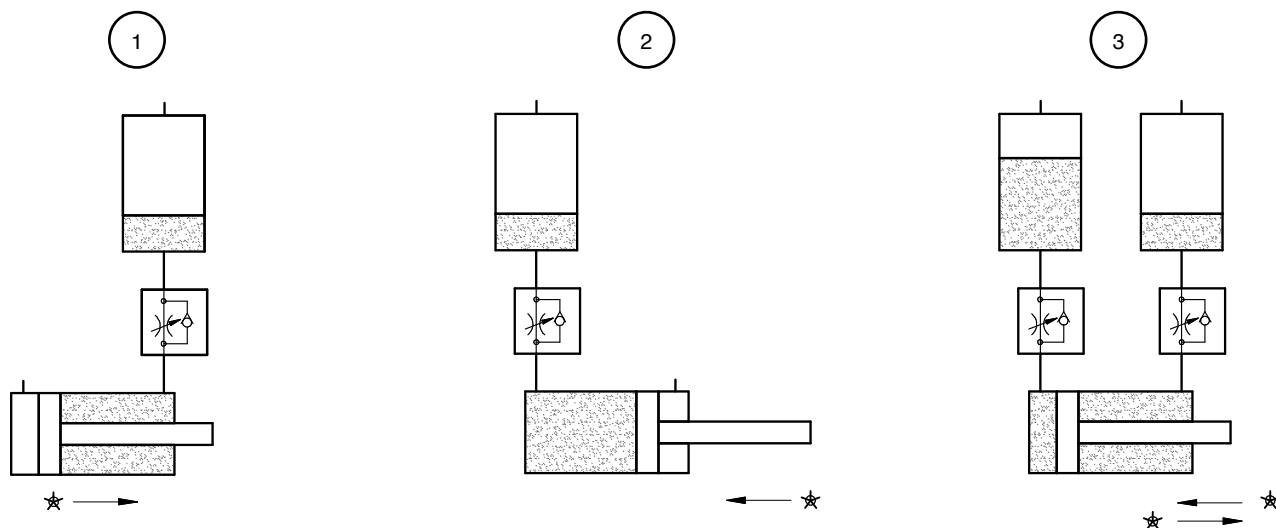

* verso di regolazione velocità stelo - control direction of rod speed

CARATTERISTICHE TECNICHE - TECHNICAL CHARACTERISTICS

Pressione di esercizio
Working pressure 1 ÷ 10 bar

Temperatura di esercizio
Working temperature -10 ÷ +70 °C (con aria secca - with dry air)

Fluido - Fluid aria compressa, filtrata, non lubrificata - compressed air, filtered, no lubrication
olio idraulico viscosità max 32 - hydraulic oil max viscosity 32

CARATTERISTICHE COSTRUTTIVE - CONSTRUCTIVE CHARACTERISTICS

Testate - Covers alluminio anodizzato - anodized aluminium

Tubo - Tube alluminio anodizzato - anodized aluminium

Guarnizioni - Seals nbr

Seeger - Retaining ring acciaio - steel

DIMENSIONI

SER

DIMENSIONS

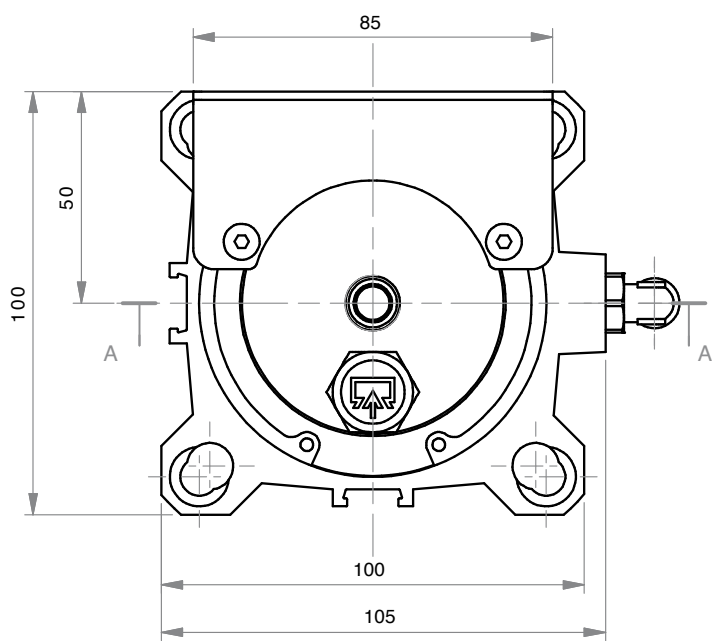
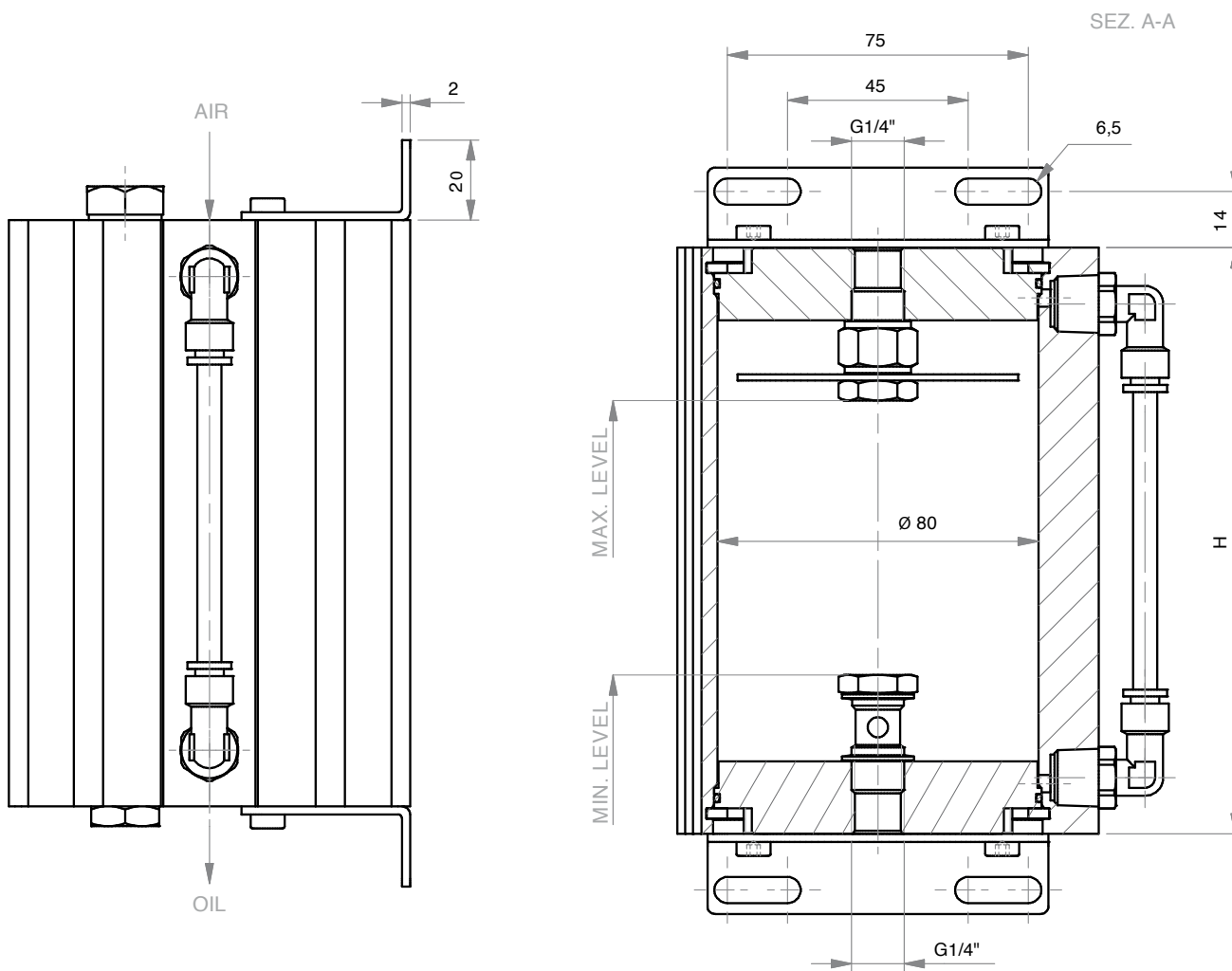

DIMENSIONI - DIMENSIONS

COD.	VOLUME [LT]	H [mm]
SER02	0,20	106
SER03	0,30	126
SER04	0,40	146
SER05	0,53	171
SER07	0,70	206
SER09	0,90	246
SER11	1,15	296
SER14	1,40	346

