

cilindri compatti guidati

guided compact cylinders



- Grande affidabilità e lunga durata
High reliability and long life time
- Versione magnetica standard
Standard magnetic version
- Sensori magnetici standard (pag. 532-535)
Standard magnetic sensors (pages 532-535)
- Alimentazione laterale o dorsale
Air ports on the top or on the side



CG	B	B	1	6	-	0	1	0
----	---	---	---	---	---	---	---	---

famiglia
product family

tipo
type

corsa
stroke

alesaggio
bore

Famiglia [product family]

CG cilindri compatti guidati [*guided compact cylinders*]

Tipo [type]

B con bronzine [*with sintered bronze rod guide*]

BB con cuscinetti a rotolamento [*with linear ball bearings*]

Materiali

Corpo: alluminio anodizzato

Stelo: C40 cromato

Piastra: acciaio nichelato

Guarnizioni: NBR e poliuretano

Guarnizione stelo: poliuretano

Materials

Body: aluminium (anodize treatment)

Piston-rod: C40 (chromium plated)

Carrier plate: nickel plated steel

Sealings: NBR and polyurethane

Piston-rod sealing: polyurethane

corse disponibili

available strokes

alesaggio corsa stroke	bore	16	20	25	32	40	50	63
10		X						
20		X	X	X				
25					X	X	X	X
30		X	X	X				
40		X	X	X				
50		X	X	X	X	X	X	X
75		X	X	X	X	X	X	X
100		X	X	X	X	X	X	X
125			X	X	X	X	X	X
150			X	X	X	X	X	X
175			X	X	X	X	X	X
200			X	X	X	X	X	X

Pressione di esercizio <i>Working pressure</i>	max 10 bar max 1 MPa
Temperatura di esercizio <i>Temperature range</i>	max +60°C
Alesaggi <i>Bores</i>	16; 20; 25; 32; 40; 50; 63 mm
Corse <i>Strokes</i>	Vedi tabella in questa pagina <i>See table in this page</i>
Fluido <i>Fluid</i>	Aria filtrata 50µ con o senza lubrificazione <i>50µ filtered, lubricated or non lubricated air</i>

cilindri compatti guidati

guided compact cylinders



6

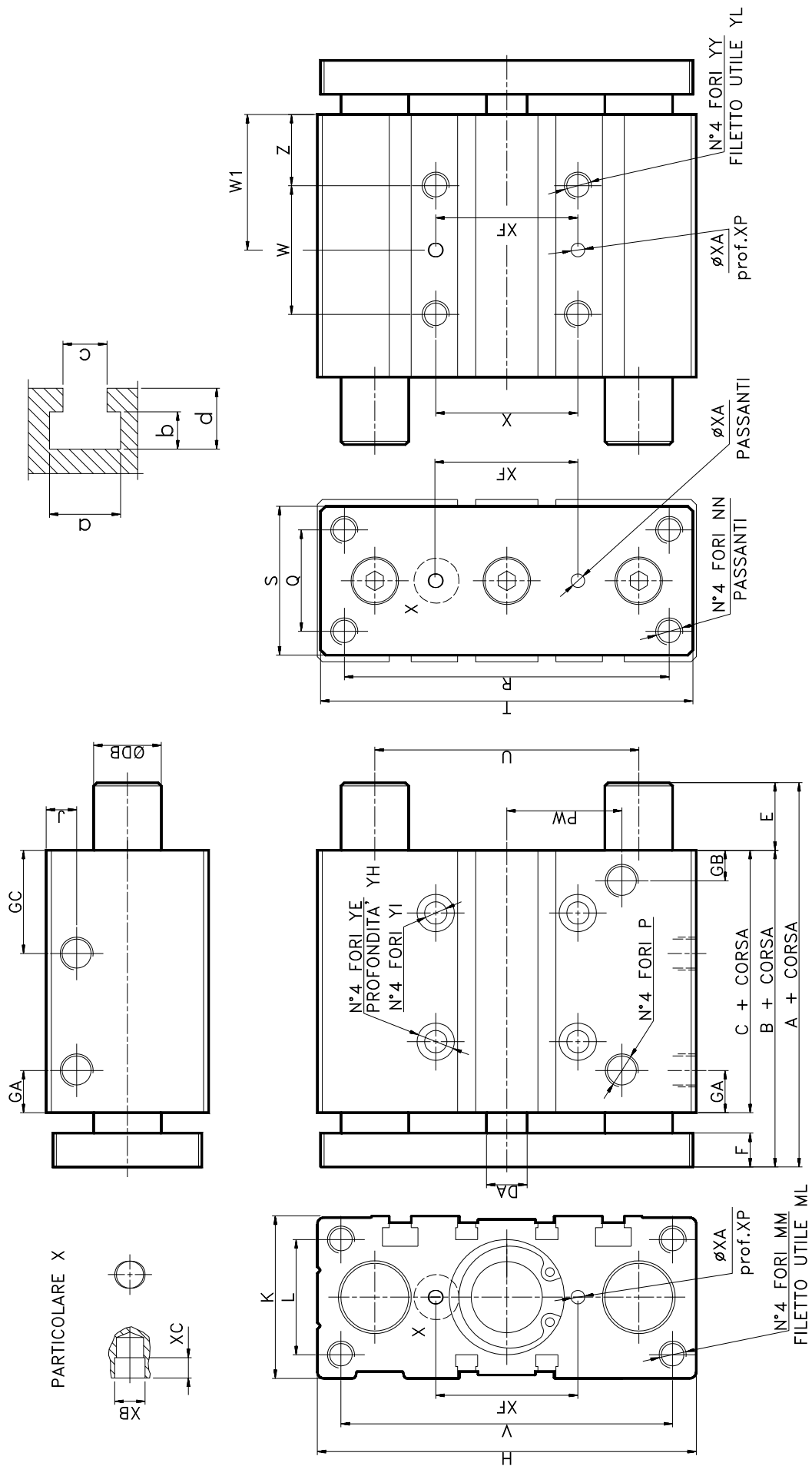

cilindri compatti guidati

guided compact cylinders



Ø	B	C	DA	F	GA	GB	GC	H	J	K	L	MM	ML	NN	P	PW	Q	R	S	T	U	V	X	YY	YL	YE	YH	YI	Z	XF	XA	XP	XB	XC	a	b	c	d
16	4.6	3.3	8	8	11	8	18	6.4	5	30	22	M5	12	M5	M5	19	16	5.4	25	62	4.6	56	2.4	M5	10	8	4.5	4.3	5	2.4	3	6	3.5	3	7.4	3.7	4.4	6.2
20	5.3	3.7	10	10	10.5	8.5	24.5	8.3	6.5	36	24	M5	13	M5	G1/8	25	18	70	30	81	5.4	72	2.8	M6	12	9.5	5.5	5.6	17	28	3	6	3.5	3	8.4	4.5	5.5	7.3
25	5.3	3.7	10	10	11.5	9	25	9.3	7.5	4.2	30	M6	15	M6	G1/8	28.5	26	78	38	91	6.4	82	3.4	M6	12	9.5	5.5	5.6	17	34	4	6	4.5	3	8.4	4.5	5.5	7.5
32	5.9	3.7	12	12	12.5	9	30.5	11.2	9	4.8	34	M8	20	M8	G1/8	34	30	96	4.4	110	7.8	98	4.2	M8	16	11	7.5	6.6	21	4.2	4	6	4.5	3	10.5	5.5	6.5	9
40	6.6	4.4	12	12	14	10	31	12.0	9	5.4	4.0	M8	20	M8	G1/8	38	30	104	4.4	118	8.6	106	5.0	M8	16	11	7.5	6.6	22	5.0	4	6	4.5	3	10.5	5.5	6.5	9
50	7.2	4.4	16	16	14	11	35	14.8	9.5	6.4	4.6	M10	22	M10	G1/4	4.7	4.0	130	60	146	110	130	6.6	M10	20	14	9	8.6	22	6.6	5	8	6	4	13.5	7.5	8.5	12
63	7.7	4.9	16	16	16.5	13.5	35	16.2	11	7.8	5.8	M10	22	M10	G1/4	5.5	5.0	130	70	158	124	142	8.0	M10	20	14	9	8.6	24	8.0	5	8	6	4	17.8	10	11	16.5

Ø		quota W (CORSE-STROKES)		quota W1 (CORSE-STROKES)	
16	24 (10-30)	4.4 (4.0-100)	17 (10-30)	27 (4.0-100)	
20	24 (20-30)	4.4 (4.0-100)	29 (20-30)	39 (4.0-100)	77 (125-200)
25	24 (20-30)	4.4 (4.0-100)	29 (20-30)	39 (4.0-100)	77 (125-200)
32	24 (25)	4.8 (50-100)	33 (25)	45 (50-100)	83 (125-200)
40	24 (25)	4.8 (50-100)	34 (25)	46 (50-100)	84 (125-200)
50	24 (25)	4.8 (50-100)	36 (25)	48 (50-100)	86 (125-200)
63	28 (25)	5.2 (50-100)	38 (25)	50 (50-100)	88 (125-200)

Ø		quota A (CORSE-STROKES)		quota E (CORSE-STROKES)		DB	
16	4.6 (10-30)	66 (4.0-100)	0 (10-30)	20 (4.0-100)	8		
20	5.3 (20-30)	85.5 (4.0-200)	0 (20-30)	32.5 (4.0-200)	12		
25	5.3 (20-30)	86 (4.0-200)	0 (20-30)	32.5 (4.0-200)	12		
32	9.7 (25-50)	107 (75-200)	37.5 (25-50)	47.5 (75-200)	20		
40	9.7 (25-50)	107 (75-200)	31 (25-50)	41 (75-200)	20		
50	106.5 (25-50)	114 (75-200)	34.5 (25)	46 (75-200)	25		
63	106.5 (25-50)	114 (75-200)	29.5 (25)	37 (75-200)	25		

Ø		quota A (CORSE-STROKES)		quota E (CORSE-STROKES)		DB	
16	4.6 (10-50)	64.5 (75-100)	0 (10-50)	18.5 (75-100)	10		
20	5.3 (20-50)	84.5 (75-200)	0 (20-50)	31.5 (75-200)	12		
25	5.3 (20-50)	85 (75-200)	0 (20-50)	31.5 (75-200)	16		
32	9.7 (25-50)	107 (75-200)	37.5 (25-50)	47.5 (75-200)	20		
40	9.7 (25-50)	107 (75-200)	31 (25-50)	41 (75-200)	20		
50	106.5 (25-50)	118 (75-200)	34.5 (25-50)	46 (75-200)	25		
63	106.5 (25-50)	118 (75-200)	29.5 (25-50)	41 (75-200)	25		

con bronzine
with sintered bronze rod guide

con cuscinetti a rotolamento
with linear ball bearings

quote W e W1
dimensions W and W1

peso in grammi [weight in grams]

Ø	10	20	25	30	40	50	75	100	125	150	175	200
16	352	402		452	502	552	752	902				
20		689		830	910	990	1310	1510	1625	1740	1855	1970
25		870		990	1080	1260	1680	2100	2500	2900	3300	3700
32			1770			2120	2770	3080	3408	3737	4066	4395
40			1990			2390	2940	3050	3460	3880	4300	4720
50			3355			3955	4755	5355	5955	6555	7155	7755
63			4030			5070	5786	6505	7224	7943	8662	9380

cilindri compatti guidati

guided compact cylinders



carichi laterali ammissibili con bronzine autolubrificanti

permissible lateral loads with self-lubricating sintered bronze guide

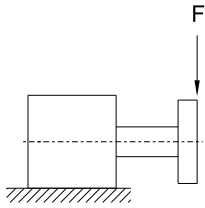

Ø mm	CARICO (N)												
16	56	40		30	25	21	30	24					
20		57		46	38	33	55	45	38	33.5	30	27	
25		93		78	68	60	81	67	60	54	48	43	
32			170				125	166	142	124	110	99	90
40			170				125	166	142	124	110	99	90
50			250				190	265	227	197	177	156	141
63			250				190	265	227	197	177	156	141
CORSE →	10	20	25	30	40	50	75	100	125	150	175	200	

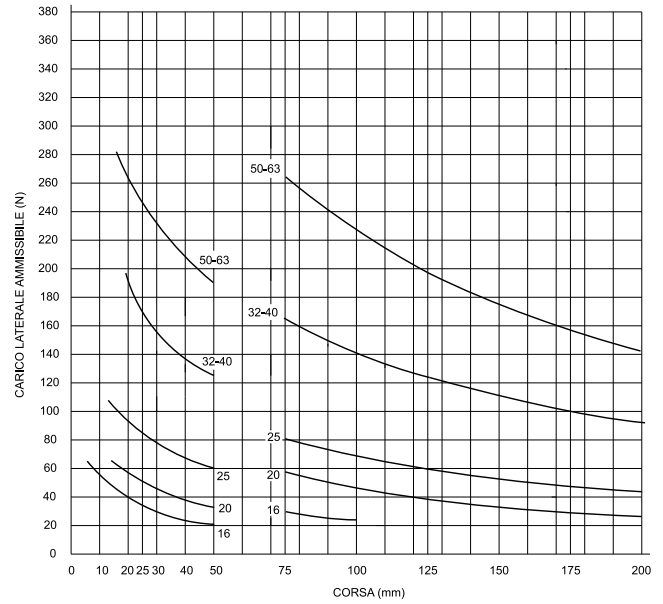

carichi laterali ammissibili con cuscinetti a rotolamento

permissible lateral loads with linear ball bearings

Ø mm	CARICO (N)												
16	44	34		27	23	21							
20		62		50	42	36	53	42	36	31	27	25	
25		94		79	68	60	59	50	43	39	35	33	
32			84			58	270	213	180	159	142	130	
40			92			64	270	213	180	159	142	130	
50			117			81	370	312	275	243	216	193	
63			117			81	370	312	275	243	216	193	
CORSE →	10	20	25	30	40	50	75	100	125	150	175	200	

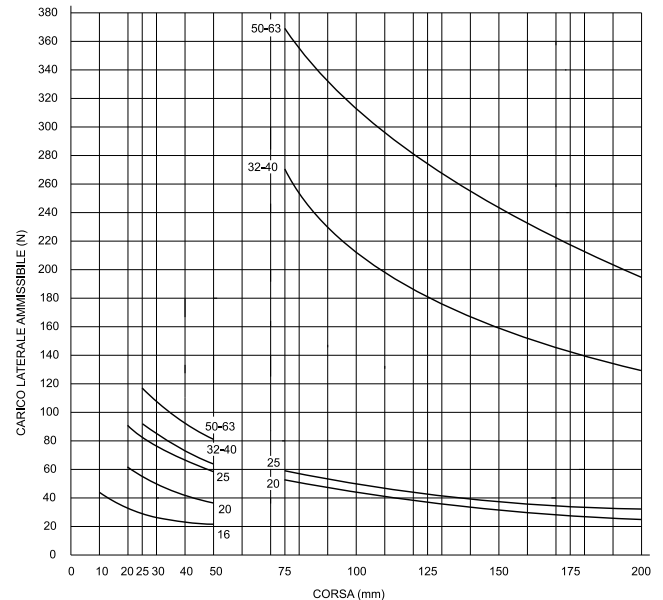

momento torcente ammissibile con bronzine autolubrificanti

permissible torque with self-lubricating sintered bronze guide

Ø mm	MOMENTO (Nm)												
16	0,65	0,51		0,42	0,36	0,32							
20		0,99		0,84	0,71	0,64	0,97	0,78	0,63	0,54	0,48	0,43	
25		1,98		1,67	1,45	1,28	1,73	1,43	1,31	1,18	1,05	0,94	
32			4,10			3,19	3,97	3,36	2,46	2,2	2	1,84	
40			4,51			3,51	4,38	3,70	2,46	2,2	2	1,84	
50			6,60			5,19	6,68	5,72	4,68	4,25	3,88	3,5	
63			6,60			5,19	6,68	5,72	4,68	4,25	3,88	3,5	
CORSE →	10	20	25	30	40	50	75	100	125	150	175	200	

momento torcente ammissibile con cuscinetti a rotolamento

permissible torque with linear ball bearings

Ø mm	MOMENTO (Nm)												
16	0,83	0,65		0,52	0,44	0,40							
20		1,20		0,96	0,81	0,69	1,02	0,93	0,82	0,71	0,64	0,58	
25		2,00		1,69	1,45	1,28	1,26	1,09	0,98	0,87	0,79	0,70	
32			2,04			1,41	6,58	5,19	4,49	3,87	3,58	3,17	
40			2,47			1,72	7,25	5,72	4,49	3,87	3,58	3,17	
50			3,22			2,22	10,17	8,58	7,75	6,86	5,99	5,30	
63			3,22			2,22	10,17	8,58	7,75	6,86	5,99	5,30	
CORSE →	10	20	25	30	40	50	75	100	125	150	175	200	

