

# cilindri pressori

*clamping cylinders*

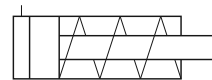

- Cilindri semplice effetto antirotazione, molla anteriore  
*Single acting front spring cylinders, anti-rotation*
- Non magnetici  
*Non magnetic*
- Ottimi per il serraggio dei pezzi da tagliare su macchine troncatrici per alluminio o legno  
*Very good cylinders to clamp the pieces in sawing machines for aluminium or wood*



modello <i>model</i>	alesaggio interno <i>internal bore</i>	corsa <i>stroke</i>	esecuzione <i>execution</i>
17.066.0	25 mm	8 mm	con tampone di spinta <i>[with pushing pad]</i>
17.062.0	25 mm	75 mm	con tampone di spinta <i>[with pushing pad]</i>
17.067.0	25 mm	110 mm	con tampone di spinta <i>[with pushing pad]</i>
17.068.0	35 mm	8 mm	con tampone di spinta <i>[with pushing pad]</i>
17.060.0	35 mm	75 mm	con tampone di spinta <i>[with pushing pad]</i>
17.061.0	35 mm	110 mm	con tampone di spinta <i>[with pushing pad]</i>
17.069.0	35 mm	75 mm	con tampone di spinta e testata anteriore filettata <i>[with pushing pad and threaded front end cap]</i>



## Materiali

Corpo: alluminio anodizzato

Stelo: AVP zincato

Guarnizioni: NBR e poliuretano

## Materials

Body: aluminium (anodize treatment)

Piston-rod: zinc plated AVP iron

Sealings: NBR and polyurethane

Pressione di esercizio <i>Working pressure</i>	2 ... 10 bar 0.2 ... 1 MPa
Temperatura di esercizio <i>Temperature range</i>	max +60°C
Alesaggi interni <i>Internal bores</i>	25; 35 mm
Corse <i>Strokes</i>	8; 75; 110 mm
Fluido <i>Fluid</i>	Aria filtrata 50µ con o senza lubrificazione <i>50µ filtered, lubricated or non lubricated air</i>

# cilindri pressori

clamping cylinders



alesaggio interno 25 mm; tutte le corse

internal bore 25 mm; all strokes

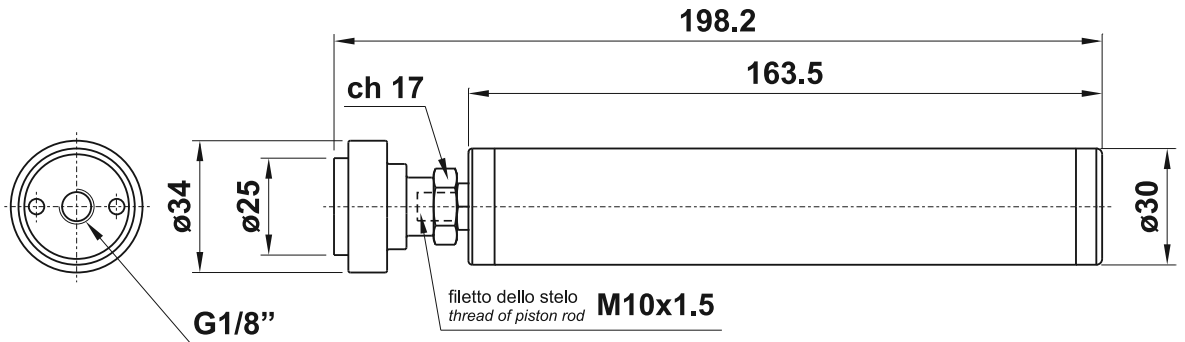

alesaggio interno 35 mm; corsa 8 mm e 75 mm

internal bore 35 mm; stroke 8 mm and 75 mm

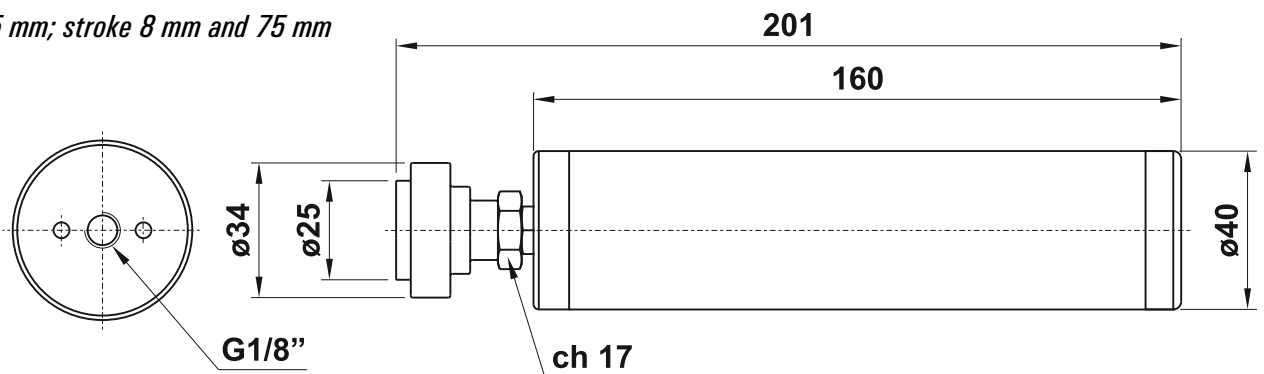

alesaggio interno 35 mm; corsa 110 mm

internal bore 35 mm; stroke 110 mm

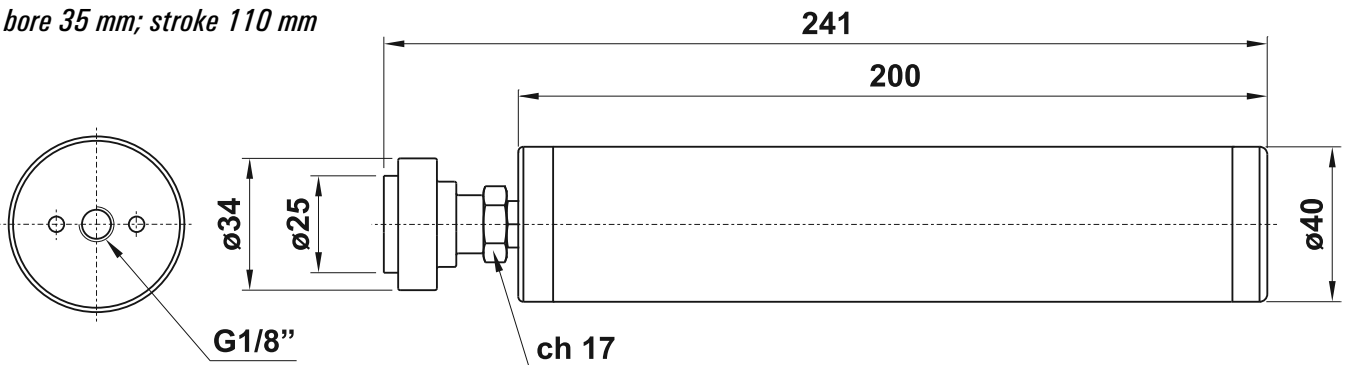

alesaggio interno 35 mm; corsa 75 mm; testata filettata

internal bore 35 mm; stroke 75 mm; threaded front end cup

