

Line 042 1/4"

Unità FR+L FR+L Unit



NEW



TT version



TC version

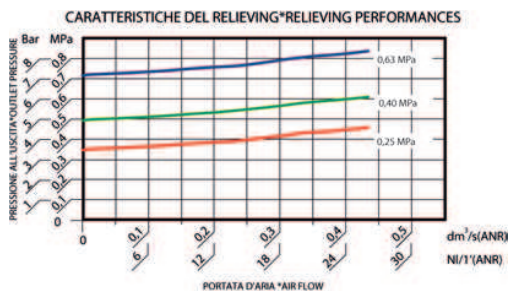
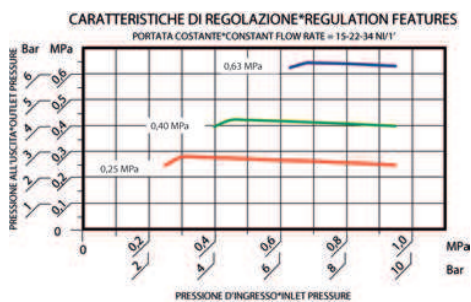
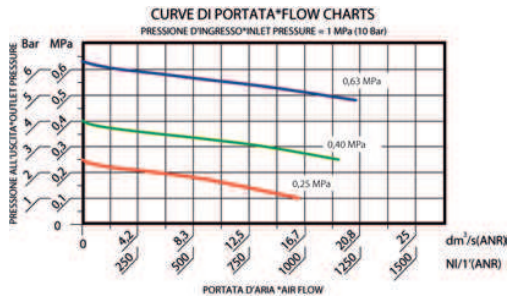
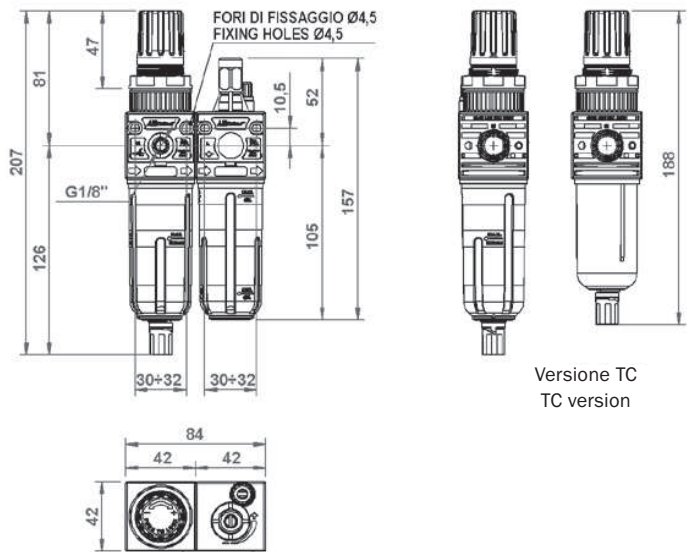

Unità FR+L

- * Unità composta da Filtroregolatore + Lubrificatore
- * Disponibile nelle versioni Tazza Trasparente (TT), con Protezione Esterna (PE) e Tazza Corta (TC).
- * Possibilità di fissaggio a parete utilizzando i fori predisposti sul corpo, con staffa tradizionale, oppure staffa a "T".
- * Campi di pressione: 0-4 Bar, 0-8 Bar (standard), 0-12,5 Bar;
- * Pressione massima di esercizio: 16,0 Bar (1,6 MPa).
- * Grado di filtrazione: 5 micron e 20 micron (standard)
- * Scarico condensa manuale e semiautomatico in versione integrata (SS), oppure nelle versioni automatiche SA e SAD.
- * Temperatura ambiente max (a 10Bar) 50 °C (122 °F)
- * Portata di riferimento (P= 6,3 Bar Δp= 1 Bar) : 980 NI/min
- * Peso : 0,32 Kg
- * Coppia di serraggio max inserti ¼ IN e OUT: 25 Nm
- * Per altre caratteristiche vedi pag. 22 (FR) e pag. 20 (L).
- * Prodotto conforme alla direttiva 2002/95/CE (RoHS)

FR+L Unit

- * Unit consisting of Filter regulator + Lubricator
- * Bowl available in three configurations: transparent (TT), transparent with outer bowl guard (PE) and short transparent version (TC).
- * Can be wall mounted using the relative holes or on brackets.
- * Pressure ranges: 0-4 Bar, 0-8 Bar (standard), 0-12,5 Bar
- * Maximum operating pressure: 16,0 Bar (1,6 MPa).
- * Filtering degree: 5 micron and 20 micron (standard)
- * Integrated manual and semiautomatic condensate drainage (SS) or SA and SAD automatic versions.
- * Maximum ambient temperature (at 10Bar) 50 °C (122 °F)
- * Reference flow rate (P= 6,3 Bar Δp= 1 Bar) : 980 NI/min
- * Weight: 0,32 Kg.
- * Max. torque inserts G ¼ IN e OUT: 25 Nm
- * Further technical features please see page 22 (FR) and page 20 (L).
- * Product complies with Directive 2002/95/CE (RoHS)



Unità con Manometro
Unit with gauge available

Esempio codice di ordinazione - Order code example
042.06.M0072 FR+L 1/4" 042 20 08R PE SS + Manometro
M = Unità completa di manometro - Unit with gauge

Line 042 1/4"

Unità F+R+L F+R+L Unit



NEW



TT version



TC version

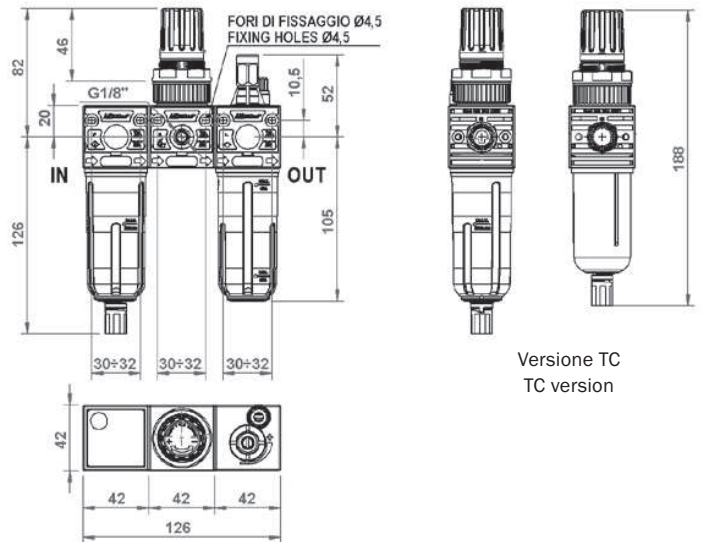

Versione TC
TC version

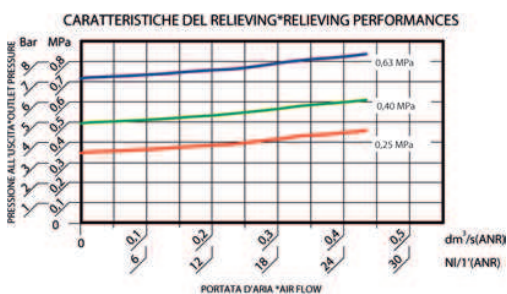
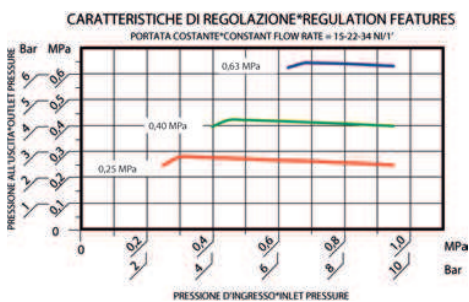
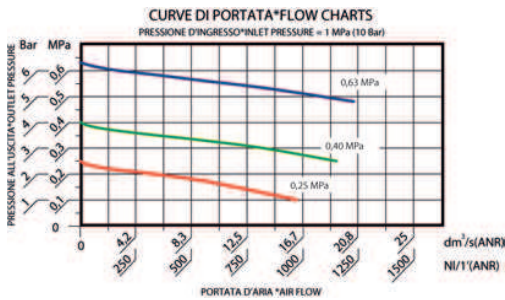

Unità F+R+L

- * Unità composta da Filtro + Regolatore + Lubrificatore
- * Disponibile nelle versioni Tazza Trasparente (TT), con Protezione Esterna (PE) e Tazza Corta (TC).
- * Campi di pressione: 0-4 Bar, 0-8 Bar (standard), 0-12 Bar
- * Grado di filtrazione: 5 micron e 20 micron (standard)
- * Scarico condensa manuale e semiautomatico in versione integrata (SS), oppure nelle versioni automatiche SA e SAD.
- * Pressione massima di esercizio: 16,0 Bar (1,6 MPa).
- * Temperatura ambiente max (a 10Bar) 50 °C (122 °F)
- * Portata di riferimento (P= 6,3 Bar Δp= 1 Bar) : 980 NI/min
- * Peso: 0,383 Kg
- * Coppia di serraggio max inserti ¼ IN e OUT: 25 Nm
- * Per altre caratteristiche vedi pag. 18 (F), pag. 16 (R) e pag. 20 (L).
- * Prodotto conforme alla direttiva 2002/95/CE (RoHS)

F+R+L Unit

- * Unit consisting of Filter + Regulator + Lubricator
- * Bowl available in three configurations: transparent (TT), transparent with outer bowl guard (PE) and short transparent version (TC).
- * Can be wall mounted using the relative holes or on brackets.
- * Pressure ranges: 0-4 Bar, 0-8 Bar (standard), 0-12,5 Bar
- * Maximum operating pressure: 16,0 Bar (1,6 MPa).
- * Filtering degree: 5 micron and 20 micron (standard)
- * Integrated manual and semiautomatic condensate drainage (SS) or SA and SAD automatic versions.
- * Maximum ambient temperature (at 10Bar) 50 °C (122 °F)
- * Reference flow rate (P= 6,3 Bar Δp= 1 Bar) : 980 NI/min
- * Weight: 0,383 Kg.
- * Max. torque inserts G ¼ IN e OUT: 25 Nm
- * Further technical features please see page 18 (F), page 22 (R) and page 20 (L).
- * Product complies with Directive 2002/95/CE (RoHS)



Unità con Manometro
Unit with gauge available

Esempio codice di ordinazione - Order code example
042.05.M0118 F+R+L 1/4" 042 20 08R PE SS + Manometro
M = Unità completa di manometro - Unit with gauge